

Compensated High Inductance Choke, 3-phase



**Description**

- Current compensated choke
- 3-phase choke
- THT-terminals
- Flange for mounting onto printed circuit board
- Fully potted resin

**Standards**

- EN 60938
- IEC 60950
- EN 55011/55014
- VDE 0871/0875

**Applications**

- Placed in front of frequency converter
- Stepper motor drives
- UPS-systems
- Inverter

**References**

**Weblinks**

[pdf](#), [html](#), [General Product Information](#), [Approvals](#), [RoHS](#), [CHINA-RoHS](#), [e-shop](#), [SCHURTER-Stock-Check](#), [Distributor-Stock-Check](#)

**Technical Data**

Rated voltage	up to 540 VAC
Rated voltage	up to 760 VDC
Rated Current	3 - 8 A @ Ta 40 °C
Rated inductance	4.0 - 50 mH, Tol. -30% +50%
Power Operating Frequency	50 - 400 Hz
Terminal technic	THT
Weight	142 - 501 g
Material: Housing	UL 94V-0
Sealing Compound	UL 94V-0

Test Voltage	2.5 kV, 50 Hz, 2 sec, winding to winding
Isolation Voltage	2.5 kV eff., 50 Hz, 2 sec, winding to ambient
Climatic Category	25/100/21 acc. to IEC 60068-1
Allowable Operation Temp.	-25 °C to 100 °C

**Dimensions**

Case 31-3P

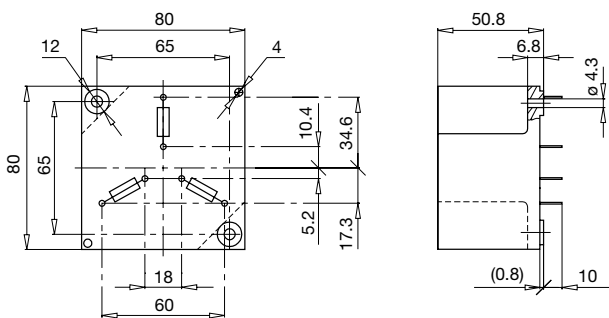

Case 46-3P

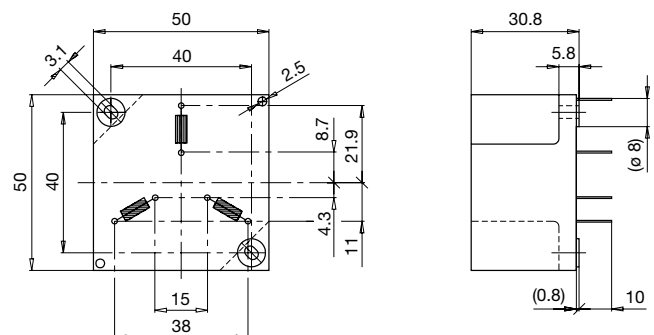

### Impedance curves

DKLL-0331-xxxx

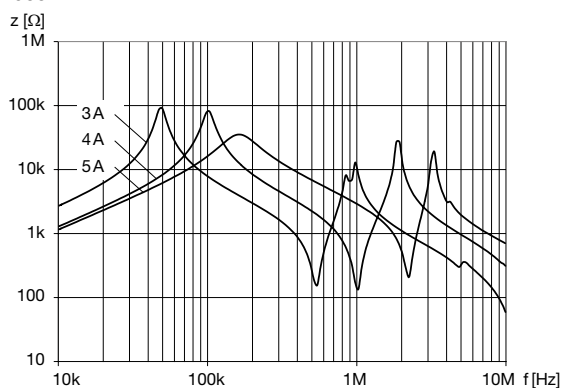

DKLL-0346-xxxx

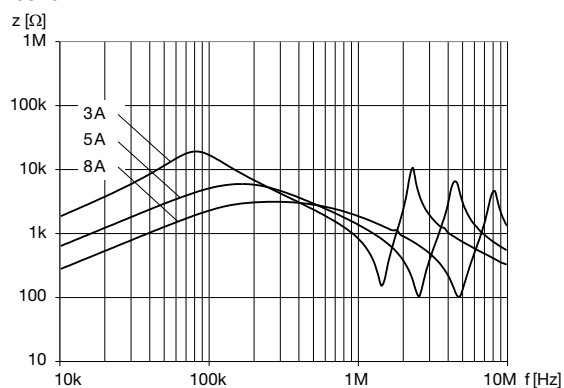

### Variants

$I_n$ [A]	$L_n$ [mH]	$R_{cu}$ [mΩ]	Tripped Power Dissipation [W]	$f_{RES}$ [MHz]	Copper $\phi$ [mm]	Weight [g]	Housing	Packing unit [pcs.]	Order Number
3	50	260	7	0.055	0.71	497	31-3P	2	DKLL-0331-0350
4	30	155	7.5	0.075	0.8	501	31-3P	2	DKLL-0331-0430
5	20	100	7.5	0.145	0.9	500	31-3P	2	DKLL-0331-0520
3	30	130	3.5	0.13	0.71	147	46-3P	10	DKLL-0346-0330
5	10	48	3.6	0.15	0.9	142	46-3P	10	DKLL-0346-0510
8	4	22	4.2	0.4	1.12	147	46-3P	10	DKLL-0346-0804